

October 22, 2019

VIA ELECTRONIC FILING

Ms. Marlene H. Dortch, Secretary
Federal Communications Commission
Office of the Secretary
445 12th Street, SW
Washington, DC 20554

! "#\$%&' () * + , - . / : ;

Dear Ms. Dortch,

On behalf of the Aerospace Vehicle Systems Institute (“AVSI”) project team, the enclosed preliminary report ‘Behavior of Radio Altimeters Subject to Out-Of-Band Interference’ is provided to the Commission in its ongoing work with GN Docket 18-122 and its potential for interference to adjacent band aviation safety systems. The AVSI preliminary report summarizes the preliminary experimental studies undertaken by the AVSI project team to characterize the behavior of Radio Altimeters (“RAs”) operating within the 4200 – 4400 MHz frequency band while exposed to adjacent radio frequency emissions in the 3700 – 4200 MHz frequency band. This data follows a previous meeting with the Commission with some of the participants to explain aviation’s concerns with potential public safety concerns for RAs from new 5G services in the adjacent 3700 – 4200 MHz band.¹

In reviewing the report, the AVSI project team wish to reiterate the report’s caveats:

- This data is considered very preliminary and has been released ahead of schedule to ensure the FCC has initial data to consider in its NPRM process.
- These initial results have been organized to account for some, but not all, potential 5G scenarios being considered by the FCC in its NPRM. Additional configurations of 5G network deployments may also need to be considered as plans for 5G are finalized.
- While the altimeters considered in the testing are representative of the majority of systems fielded by commercial and private aviation, it is not a comprehensive set of data for all altimeters operating under all conditions. Therefore, an additional variance in performance should be expected and accounted for as plans for 5G are finalized.
- This report does not consider the operational interactions between aircraft and wireless base stations/user equipment. The AVSI project team strongly recommends that any study consider the worst-case flight and 5G deployment scenarios to ensure all possible RF interactions with RAs can assure flight safety, including with the involvement of the Federal Aviation Authority (“FAA”) to assure public safety in the national airspace. Studies should also include necessary extra safety margin to account for unknown elements in any analysis as required by International Civil Aviation Organization (“ICAO”) when conducting such studies.

¹ See Letter from Andrew Roy on behalf of the Aviation and Aerospace Participants concerning the ongoing AVSI radio altimeter testing, GN Docket 18-122 (dated 6 Sep 2019).

The AVSI will continue to develop and validate the testing given the number of variables that must be accounted for and the potential range of aviation systems to be accounted for. A copy of the report has also been sent to the FAA, and is intended to form the basis of a new international aviation standard at ICAO once the testing has been fully completed and validated by the international aviation community.

Respectfully submitted,

/s/ David Redman

Dr. David Redman – Aerospace Vehicle Systems Institute
On behalf of the AVSI AFE 76s2 project team

cc:

Julius Knapp

Michael Ha

Ira Keltz

Kenneth Baker

AFE 76s2

Preliminary Report: Behavior of Radio Altimeters Subject to Out- Of-Band Interference

Authors: Aerospace Vehicle Systems Institute
AFE 76s2 Project Members

Date: 22 October 2019
Issue: 1.0

Release Status: Public
Approved: Oct 22, 2019

Document Revisions

REV	DATE	Author(s)	Modifications	Approved
1.0	10/22/2019	A.Roy, C. Barber, S. Frick, D. Redman, E. Straub	Document completion ready for public release	10/22/2019
1.1	12/06/2021	D. Redman	Removed watermark	

Acknowledgements

The members of the AVSI AFE 76s2 Project that contributed to this research included

Airbus	Uwe Schwark, Thomas Meyerhof, Jean-Luc Robin, Laurent Azoulai, Claude Pichavant
ASRI	Andrew Roy
AVSI	David Redman, Fred Fisher, Josh Ruff, Inderdeep Singh
Collins Aerospace	Radek Zakrzewski, Howard Tetrault
Embraer	Luiz Souza, Aristides Cintra
FAA	Mike Biggs
Garmin	Eddie Straub, Clay Barber
Honeywell	Seth Frick
Lufthansa Technik	Steffen Mersch
NASA	Truong Nguyen, Gary Hunter, Sky Yarlborough
Safran	Steve Rines, Oliver Lücke
Thales	Philippe Bontemps, Stephane Tallet, Ivan Martin

Table of Contents

Document Revisions	i
Acknowledgements	ii
Table of Contents	iii
List of Figures	v
List of Tables	vi
List of Acronyms	vii
Disclaimer	ix
1. Introduction	1
1.1. Motivation	1
1.2. AVSI	2
2. Background	2
2.1. Usage of Radio Altimeters	2
2.2. Operation of Commercial Radio Altimeters	2
2.3. Existing Sources of Interference	4
2.3.1. In-Band Interference	4
2.3.2. Out-Of-Band Interference	5
2.4. Operational Scenario Considerations	5
3. Test Methodology	6
3.1. General Approach	6
3.1.1. Altitude Simulation	6
3.1.2. Interference Simulation	8
3.2. Experimental Setup Details	9
3.2.1. Aggressor RA Simulation	9
3.2.2. OoBI Signal Simulation	10
3.2.3. Attenuation Calibration	11
3.2.4. Other elements of the experimental setup	11
3.3. Experimental Procedure	11
3.3.1. Out of Band Interference Signals	11
3.3.2. Tests at Multiple Altitudes	13
3.4. Threshold Power Criteria	14
3.4.1. Definition of Correct Height	14
3.4.2. Interference Power Threshold	15
4. Preliminary Test Results	16

4.1. Aggregate Test Results for Altimeters at 200 Feet.....	16
4.2. Aggregate Test Results for Altimeters at 1000 Feet.....	17
4.3. Aggregate Test Results for Altimeters at 2000 Feet.....	18
4.4. Commentary on Preliminary Results	18
5. Summary and Initial Conclusions	21

List of Figures

Figure 1: Simplified top-level architecture of a direct-conversion FMCW altimeter.	3
Figure 2: Transmitted (TX) and received (RX) FMCW signals.	3
Figure 3: Block Diagram of the Test Setup.	8
Figure 4: 300 MHz OoBI Waveform Centered at 3850 MHz Pictured on a Spectrum Analyzer.	10
Figure 5: Typical Power Sweep Plot.	12
Figure 6: Typical Statistical Plot.	13
Figure 7: Aggregate Plot of Altimeter Break Points, 200 Feet.	16
Figure 8: Aggregate Plot of Altimeter Break Points, 1000 Feet.	17
Figure 9: Aggregate Plot of Altimeter Break Points, 2000 Feet.	18
Figure 10: Minimum Break Points of Altimeter Types 1 – 6 for Each Altitude Tested.	19
Figure 11: Minimum Break Points of Altimeter Type 7 for Each Altitude Tested.	20

List of Tables

Table 1: Aggressor VCO Signal Characteristics for 200' Test Case (Centered at 4300 MHz)	9
Table 2: Own ship VCO Signal Characteristics (Centered at 4300 MHz)	9
Table 3: VSG Signal Parameters for OoBI Simulation.....	12

List of Acronyms

AID	aircraft installation delay
AFE	authority for expenditure
ARINC	formerly Aeronautical Radio, Incorporated, now part of SAE Industry Technologies Consortia (SAE ITC).
ASRI	Aviation Spectrum Resources, Inc.
AVSI	Aerospace Vehicle Systems Institute
BPSK	binary phase-shift keying
dB	decibel
dB _i	decibel-isotropic
dB _m	decibel-milliwatts
EMC	electromagnetic compatibility
EUROCAE	European Organisation for Civil Aviation Equipment
FAA	U.S. Federal Aviation Administration
FCC	U.S. Federal Communications Commission
FMCW	frequency modulated continuous wave
FSMP	Frequency Spectrum Management Panel (part of ICAO)
FS	Fixed Service
FSS	Fixed Satellite Service
IATA	International Air Transport Association
ICAO	International Civil Aviation Organization
IF	Intermediate Frequency
ILS	Instrument Landing System
IRIG	inter-range instrumentation group time codes
ITU-R	International Telecommunication Union - Radiocommunication Sector
LO	Local Oscillator
MHz	megahertz
MOPS	Minimum Operational Performance Standards
NASA	U.S. National Aeronautics and Space Administration
NCD	no computed data
OFDM	orthogonal frequency-division multiplexing
PSD	power spectral density
RA	radio altimeter

RF	radio frequency
RX	Receive (as in received radar signal)
RTCA	RTCA, Inc. (formerly Radio Technical Commission for Aeronautics)
TAMU	Texas A&M University
TX	Transmit (as in transmitted radar signal)
USB	Universal Serial Bus
VCO	voltage-controlled oscillator
VSG	vector signal generator
WAIC	Wireless Avionics Intra-Communications
WCLS	Worst-Case Landing Scenario
WRC	World Radiocommunication Conference

Disclaimer

The information provided in this report is part of an ongoing effort to fully characterize the radio frequency performance of radio altimeters and is subject to further work and review. However, given current regulatory timelines in the United States and from other administrations, this work is being released prematurely to ensure initial information is publicly available. Any use of this report's information should include such a caveat until further studies and validation have been completed.

1. Introduction

This report summarizes the preliminary experimental studies undertaken by the Aerospace Vehicle Systems Institute (AVSI) to characterize the behavior of Radio Altimeters (RAs) operating within the 4200 – 4400 MHz frequency band while exposed to adjacent radio frequency (RF) emissions in the 3700 – 4200 MHz frequency band. The overarching goal of the study was to determine the sensitivity of representative commercial RAs to out-of-band interference (OoBI), as specified by the International Civil Aviation Organization (ICAO) to investigate radio altimeter RF susceptibility.¹ While the testing group could not feasibly acquire every RA model currently in use, the units obtained were known to be common to many airframes and thus represent the majority of RAs currently in use.

The report first provides background information describing the motivation for this study and details concerning the operational RF environment currently experienced by RAs. The report then provides a description of the experimental setup followed by a summary of the test results. Then follows a discussion that uses these results to infer the behavior of RAs in response to the potentially new RF environment in the 3700 – 4200 MHz band.

1.1. Motivation

The 3700 – 4200 MHz frequency band immediately below the RA band has previously been occupied by Fixed (FS), and Fixed-Satellite (space-to-Earth) (FSS) in the United States.² Altimeters were designed to operate robustly in these environments, but any proposed changes to frequency allocations now must be carefully examined to understand the potential impact to RA operation and by extension to the safety of commercial and private aviation operations.

Recent interest in new mid-band spectrum for potential 5G mobile telecommunications use prompted the Federal Communications Commission (FCC) to begin a review of new mobile services in the 3700-4200 MHz band. Established under GN Docket No. 18-122 titled “Expanding Flexible Use of the 3.7 GHz to 4.2 GHz Band”, the resulting Notice of Proposed Rulemaking (NPRM) acknowledged the co-primary allocations for RAs and Wireless Avionics Intra-Communications (WAIC) in the adjacent 4.2-4.4 GHz band and sought comment on adopting power limits for point-to-multipoint FS operations in the 3.7-4.2 GHz band:

“We note that the adjacent 4.2-4.4 GHz band is allocated to the aeronautical radionavigation service on a primary basis and that, at WRC-15, the 4.2-4.4 GHz band was also allocated to the aeronautical mobile (R) service on a primary basis in all ITU Regions with use reserved for WAIC systems. WAIC systems are onboard short range wireless systems that will replace substantial portions of aircraft wiring. These systems increase aircraft safety by providing dissimilar redundancy in communications links between aircraft systems. We solicit comment on the needed out-of-band emission limit required to protect the aeronautical radionavigation service in the 4.2-4.4 GHz band.”³

¹ Job Card FSMP.006.01, *Develop radio frequency and interference rejection characteristics for radio altimeters*, International Civil Aviation Organization (2016).

² *Radio Regulations, Volume 1, Articles, Edition 2016*, International Telecommunication Union, p. 125 (2016).

³ *Expanding Flexible Use of the 3.7 to 4.2 GHz Band*, GN Docket No. 18-122, Order and Notice of Proposed Rulemaking, 33 FCC Rcd 6915 (11) (2018).

The aviation and aerospace industries have filed comments several times with the FCC to request that the adjacent band safety services are protected.⁴ In follow-up discussions with the FCC since these filings, the FCC has requested that the aerospace industry provide input on the susceptibility of RAs to unwanted emissions from the 3700 – 4200 MHz band so it can use this information in its considerations.

1.2. AVSI

AVSI is an aerospace industry research cooperative based at Texas A&M University (TAMU) that facilitates pre-competitive research projects among its members, which include organizations from the aerospace industry, related government agencies, and academia. This project (AFE 76s2) was organized under AVSI to empirically determine in a laboratory setting the transmission characteristics of OoBI that degrade RA performance. AVSI/TAMU provided a neutral, standard test setup that supported “black-box” testing of commercial RAs — altimeters were tested without knowledge of proprietary features of the equipment by providing stimuli through the externally accessible receive port of the altimeter and while monitoring the reported altitude on the standard avionics bus output. Project members contributed material resources and technical expertise. Contributors to this project included Airbus, Aviation Spectrum Resources, Inc. (ASRI), Collins Aerospace, Embraer, U.S. Federal Aviation Administration (FAA), Garmin, Honeywell, International Air Transport Association (IATA), Lufthansa Technik, U.S. National Aeronautics and Space Administration (NASA), Safran, Texas A&M University, and Thales.

2. Background

2.1. Usage of Radio Altimeters

The radio altimeter is a core aviation navigational system that provides a continuous report of the aircraft’s height above terrain during all phases of flight. The system is a critical safety function in landing/take-off, low level maneuvering, and avoiding changes in terrain that may not be visible at night or during bad weather. Altimeters were widely introduced after a number of aviation incidents up to the 1970’s of aircraft flying unintentionally into the ground – a circumstance formally known as controlled flight into terrain. The radio altimeter has significantly improved aviation safety for all aircraft types since its introduction and is now an essential component of automated landings, which increases the safety and efficiency of air travel. Over 55,000 aircraft across the U.S. are now equipped with radio altimeters including large commercial aircraft, helicopters and private aircraft, as well as the many thousands of international aircraft entering US airspace every day. Medium to large aircraft are often fitted with two or three altimeters operating simultaneously for redundancy as part of the minimum equipment list, given their importance to safety of flight.

2.2. Operation of Commercial Radio Altimeters

All RAs tested to date as part of AFE 76s2 utilize Frequency Modulated Continuous Wave (FMCW) radar operation. Most FMCW radio altimeters utilize a direct-conversion architecture, as shown in Figure 1. Note that this diagram is highly simplified and omits many components which would typically be included in a practical design. This includes receiver components which may greatly affect the RA

⁴ See, e.g., Letter from Aeronautical Frequency Committee, Aerospace Industries Association, Aircraft Owners and Pilots Association, Air Line Pilots Association, Airlines for America, Helicopter Association International, International Air Transport Association, General Aviation Manufacturers Association, National Business Aviation Association, and National Air Transportation Association, to Marlene H. Dortch, Secretary, FCC, GN Docket No. 18-122 (filed June 19, 2019).

performance in the presence of OoBI, such as a low-noise amplifier (LNA) and RF preselect filter. However, the diagram is sufficient for understanding the basic operation of FMCW altimeters and how they may be affected by various types of RF interference.

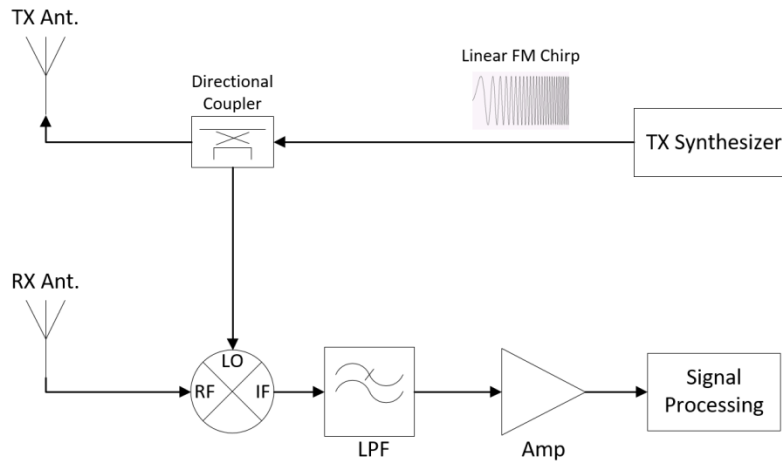

Figure 1: Simplified top-level architecture of a direct-conversion FMCW altimeter.

FMCW altimeters continuously transmit a series of linear frequency sweeps, also known as chirps. These chirps consist of a transmitted frequency which linearly increases with time (an up-chirp) or which linearly decreases with time (a down-chirp). The sequence of chirps may include both up-chirps and down-chirps (such as the triangular FMCW waveform as shown in Figure 2), chirps only in one direction (a sawtooth FMCW waveform), or periodic discontinuous variants of these basic waveforms. The chirp rate ($\frac{F_2 - F_1}{T}$ in MHz/msec) is an operational parameter that varies between altimeter models and may also be designed to vary based on altitude while in flight.

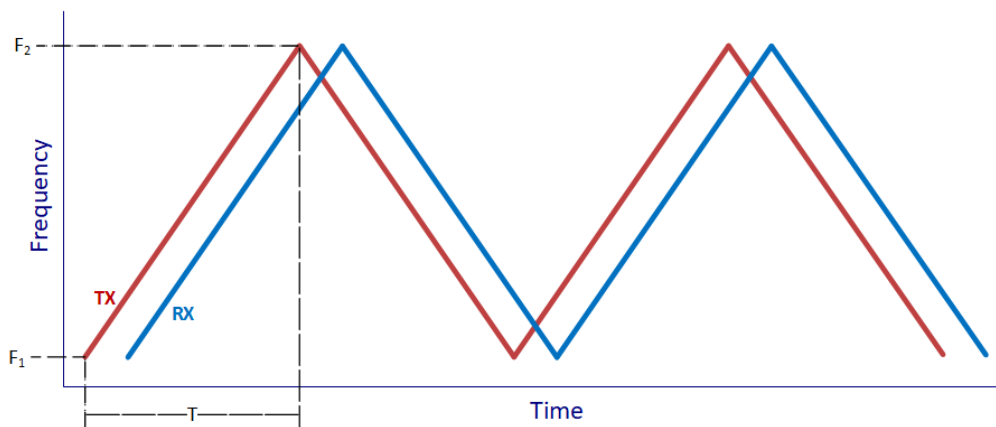

Figure 2: Transmitted (TX) and received (RX) FMCW signals.

The transmitted chirp signals (TX) propagate downward from the aircraft via the RA TX antenna, reflect off the terrain below, propagate back to the aircraft, and are received by the altimeter via the RA RX antenna. The received signal (RX) is thus a delayed and attenuated version of the transmitted signal. Since the chirp signals have a linear relationship between frequency and time, the instantaneous difference in frequency between the transmitted signal and the received signal is directly proportional

to time delay and thus the altitude of the aircraft. Therefore, the total time delay of the received signal can be calculated by mixing the received and transmitted signals and determining the difference or beat frequency. The altitude of the aircraft above the terrain is then determined from this time delay utilizing the known speed of radio waves through air (the speed of light) and applying a factor of one-half to account for the round-trip propagation time of the signal.

To facilitate this mode of operation in a direct-conversion architecture, the transmitted signal itself or a delayed copy thereof, is used as the local oscillator (LO). The receiver LO is thus also continuously sweeping in frequency, which introduces some complication when performing interference analysis. This complication introduces greater difficulty in predicting the response of FMCW altimeters to external RF interference than that of traditional heterodyne receivers, and thus empirical methods of analysis are highly favored. This is particularly necessary for interference sources which are outside of the sweep or chirp bandwidth of the altimeter.

Commercial altimeters report altitude on the avionics bus up to 40 readings per second to an accuracy of 3 ft or better. Even for straight and level flight in a hypothetical environment free from RF interference, altimeters must compute reliable height above ground level while the RX signal fluctuates greatly due to natural variations in the reflected terrain signal. Altimeters thus use filtering and analog or digital signal processing techniques to reliably compute height from the intermediate frequency (IF) signal spectrum. While specific features of the signal processing used in any given altimeter design are proprietary, modern RAs generally use some form of Fourier transform and averaging techniques to compensate for the dynamics of the RX signal. However, when the LO is mixed with real signals received through the receive antenna of an RA, the IF signal contains not only the primary desired beat frequency between the TX and RX signal, but also any dynamic RF interference signals that are mixed into the IF bandwidth.

2.3. Existing Sources of Interference

2.3.1. In-Band Interference

2.3.1.1. Own-Ship Radio Altimeters

The strongest source of in-band RF interference that RAs must contend with is other RAs operating on the same aircraft in multiplex (multiple unit) installations. Most commercial air transport and larger business aviation aircraft, as well as some helicopters, utilize dual RA installations to provide redundancy and improved reliability. Some large commercial air transport aircraft utilize triplex RA installations for even greater redundancy and reliability. In both these situations, the RAs are designed to operate successfully with other collocated RAs of the same type. The RAs will often make subtle changes to their transmit waveform characteristics to prevent persistent correlations between RA transmissions, which could lead to harmful interference effects. In most general aviation and many business aviation and helicopter applications, however, only a single RA will be installed on each aircraft and this type of interference is not a concern.

2.3.1.2. Radio Altimeters Aboard Other Aircraft

In addition to potential own-ship RAs, the RAs installed on other aircraft will produce in-band RF interference. This interference will equally affect RAs on all type of aircraft, regardless of whether or not the victim aircraft utilizes a multiplex installation. The significance of RA interference from other aircraft depends greatly on the geometry between the victim and aggressor aircraft and thus on the operational scenario. For most phases of flight this type of interference will be negligible and not affect RA performance. However, if the victim aircraft is operating near a high concentration of other aircraft within

the field of view of the RA receive antenna, such as during the final approach and landing phases of flight or airport flyover scenarios, the RA interference from other aircraft may be significant. Nevertheless, RAs have successfully operated in this environment for many decades without major issues, indicating that existing designs have sufficient margin to tolerate such interference.

2.3.1.3. WAIC Systems Aboard Other Aircraft

Although WAIC has been granted a spectrum allocation for aeronautical mobile (R) service in the 4200 – 4400 MHz band on a co-primary basis with RAs, the operational requirements and industry standards for WAIC are still in development. As such, no WAIC systems are currently deployed and thus RAs have not been operating with in-band interference from WAIC. Given the language of Resolution 424 at WRC-15,⁵ it is understood that the design and installation of WAIC systems will ensure that no harmful interference is posed to RAs aboard the same aircraft. Further, although it will be possible for WAIC systems to interfere with RAs on other aircraft, the development community is currently undergoing efforts to characterize such interference and minimize its impact to RAs through appropriate operational requirements. These efforts have included experimental testing undertaken by AVSI in a separate project, which has demonstrated adequate safety margin for RAs under worst-case conditions for WAIC interference.

Because WAIC is not an existing source of interference in the operational RF environment for RAs and steps are being taken by industry and regulators to mitigate any potential risk of harmful in-band interference from WAIC systems on RAs, WAIC signals were not considered in the present study.

2.3.2. Out-Of-Band Interference

The existing RF interference environment in which RAs operate includes a wide variety of sources outside of the 4200 – 4400 MHz band. In this existing environment, it is known to be extremely rare for RA performance to be degraded as a result of OoBI, and any such instances are most often due to installation issues resulting in poor electromagnetic compatibility (EMC) between the RAs and other radio transmitters on the same aircraft. However, it should be noted that the 3700 – 4200 MHz band in the present interference environment is occupied by fixed and satellite services which pose little threat to RAs due to their operational characteristics. This situation may not be the case in the future, however, if the use of these bands is expanded or changed significantly, as demonstrated in the present study.

2.4. Operational Scenario Considerations

The laboratory tests described in Section 3 of this report were carried out to determine the interference susceptibility thresholds of several representative RA models in operation aboard air transport, business, and general aviation fixed-wing aircraft as well as helicopters (hereafter referred to as altimeters Type 1 through Type 7) to OoBI in the 3700 – 4200 MHz frequency band. To assess whether interference susceptibility thresholds were exceeded in any operational flight phase of such aircraft, the AVSI project team assessed multiple scenarios at multiple altitudes with respect to the effect on the RAs aboard the victim aircraft. This included multiple altitudes of aircraft operation from 200 to 2000 ft. The laboratory testing also included interference from RAs aboard other aircraft, as well as two redundant RAs aboard the victim aircraft itself to model the current RF operating environment for RAs.

Three operational scenarios were considered. First, a “worst-case landing scenario” (WCLS) was considered in which the victim aircraft is at an altitude of 200 feet while crossing the runway threshold just prior to landing, while a large number of other aircraft are operating nearby on the taxiway and

⁵ Resolution 424 (WRC-15), *Use of Wireless Avionics Intra-Communications in the Frequency Band 4 200-4 400 MHz*, in *Final Acts, WRC-15 World Radiocommunication Conference (Geneva, 2015)*, ITU, p. 320-321 (2016).

apron of the airport. Each of the aircraft on the ground produces in-band interference from their RAs, with the interference path losses from each aggressor RA to the victim RA computed based on the scenario geometry dictated by ICAO aerodrome design guidelines. The WCLS was developed and validated by AVSI to represent the overall worst-case existing interference environment for RAs in fixed-wing applications,⁶ while simultaneously considering the most safety-critical phase of flight during which the reported altitude from the RAs must be highly reliable to ensure safe operation of the aircraft. The AFE 76s2 project team, which included RA and aircraft manufacturers, agreed that this scenario represents simultaneously the worst-case RA interference geometry and the most safety-critical phase of flight.

The second and third operational scenarios considered the victim aircraft flying at altitudes of 1000 and 2000 feet, respectively. While some RAs operate to higher altitudes, the minimum altitude range for RAs based on current FAA certification requirements is 2500 ft. Thus, testing at 1000 ft and 2000 ft provided realistic operational scenarios in the middle and upper ends of the required altitude range. In both cases, due to the extremely large path loss of the interference signals, the in-band interference from RAs aboard other aircraft is negligible and may be ignored, even when operating nearby a busy airport such as in the WCLS. Thus, the only in-band interference sources in these scenarios are the own-ship RAs. These scenarios are highly generalized and are applicable to any type of aircraft operating at these altitudes, including fixed-wing aircraft and helicopters. While these higher altitude scenarios generally do not have the same level of flight safety criticality as the WCLS, they are important to consider because at higher altitudes RAs must process substantially weaker ground reflection signals than at lower altitudes and thus have increased sensitivity. This increased sensitivity may also lead to increased susceptibility to OoBI.

3. Test Methodology

3.1. General Approach

The AVSI project team established a reference test bench at TAMU that simulated the scenarios described in Section 2.4 to characterize the performance of a representative set of widely deployed commercial RAs subject to this interference environment. Details of the test setup are shown in Figure 3 and are described below.

3.1.1 Altitude Simulation

The basic test setup specified in EUROCAE ED-30, which describes the Minimum Operational Performance Standards (MOPS) for radio altimeters, calls for an altitude simulator connected between transmit and receive ports of the RA under test.⁷ The simulator attenuates and delays the signal transmitted by the RA in a manner that is representative of actual signal paths for various altitudes. Figure 3 shows the transmit signal as green arrows from one of three altimeter models mounted in a test chassis and the delayed and attenuated signal using red arrows. In the AVSI test bench, signal delay is created using an optical delay line with fixed length fiber spools that provide delays corresponding to 200, 1000, and 2000 feet. Attenuation is set in accordance with the methods outlined

⁶ ICAO Information Paper: Radio Altimeter Interference Susceptibility Testing Status Update, [Published at ICAO Frequency Spectrum Management Panel](#), 6 – 13 Sep 2018

⁷ ED-30, *Minimum Performance Specification for Airborne Low Range Radio (Radar) Altimeter Equipment*, EUROCAE (1980).

in RTCA DO-155⁸ for these specific altitudes through a combination of fixed and variable attenuators in addition to the intrinsic attenuation of the optical delay line.

The nominal loop loss used for all three test scenarios corresponds to the minimum terrain reflection coefficient (known as $\sigma_0(0)$) of 0.01 as called out in the test procedures of EUROCAE ED-30, which is the most stringent testing condition identified in the MOPS. Further, an antenna gain of 10.8 dBi and an antenna beamwidth of 60° was assumed for all test scenarios and RAs under test, which is representative of the majority of installations (though it should be noted that some aircraft antennas can have higher gain). For an altitude of 200 feet, this yields an external loop loss of 90 dB, referenced to the transmit (TX) and receive (RX) antenna ports of the RA. For an altitude of 1000 feet, the external loop loss is 104 dB, and for 2000 feet it is 110 dB. In addition, a total of 6 dB of RF cable losses were assumed (3 dB for the TX cable and 3 dB for the RX cable), representing typical installation conditions on many types of commercial aircraft. Therefore, the nominal total loop losses referenced at the TX and RX ports on each RA under test were 96 dB at 200 feet, 110 dB at 1000 feet, and 116 dB at 2000 feet.

RA's are typically calibrated to report 0 feet when the aircraft is on the ground, taking into account the height of the fuselage above the tarmac and RF cable delays between the altimeter and the TX and RX antennas. In these tests, this installation calibration was not performed and, as a result, each RA under test reported altitude values with a slightly different (but consistent) offsets. However, all performance evaluations were based on changes in altitude output relative to a measured baseline value in each scenario, and thus the small constant altitude offsets are ignored. This approach was confirmed to be acceptable by each of the RA manufacturers.

⁸ DO-155, *Minimum Performance Standards-Airborne Low-Range Radar Altimeters*, RTCA, Inc. (1974).

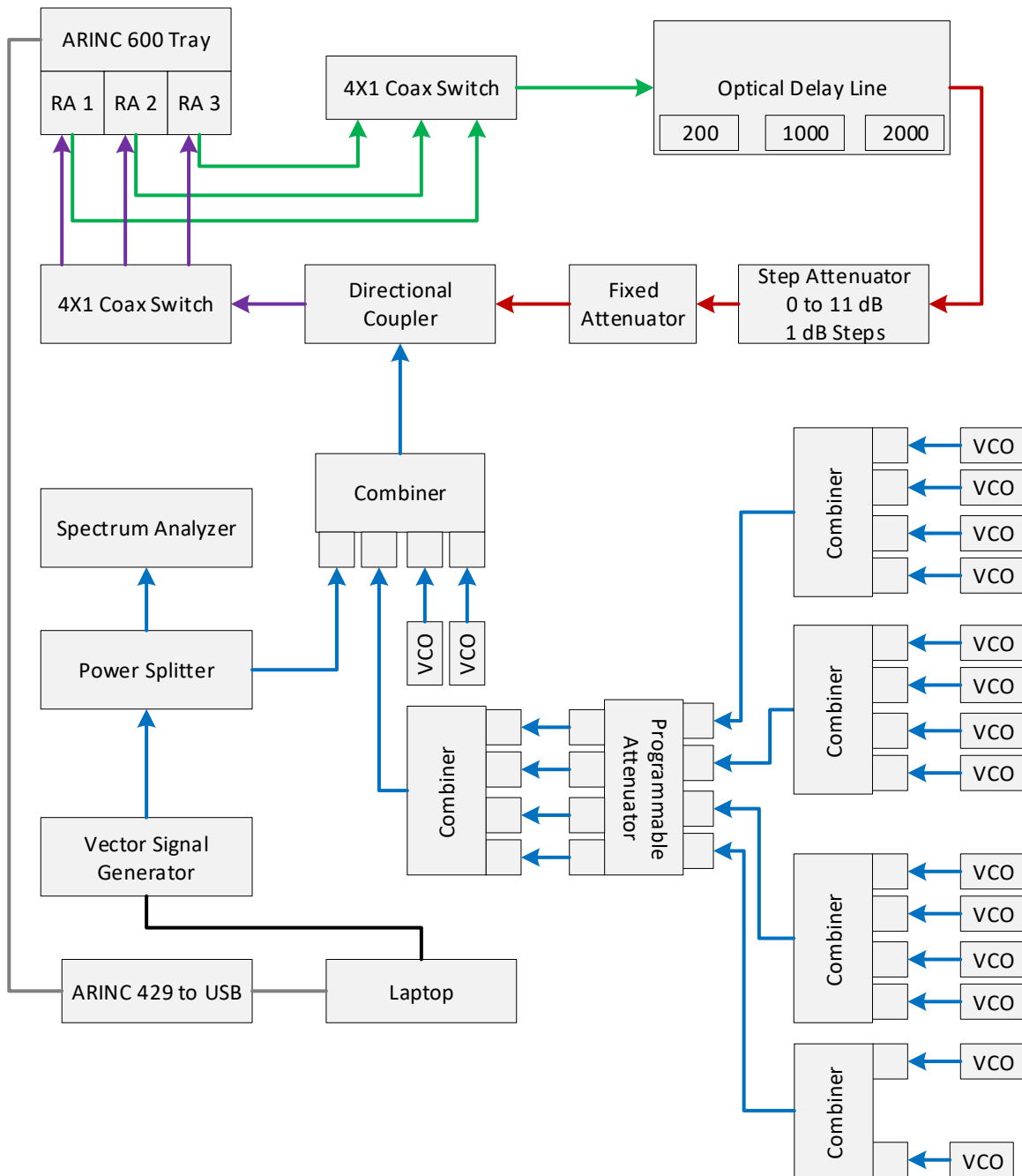

Figure 3: Block Diagram of the Test Setup.

3.1.2 Interference Simulation

The AVSI test bench has the capability to simulate both in-band interference from FMCW sources representing other RAs both on the same aircraft and on other aggressor aircraft, as well as generic in-band or out-of-band interference signals produced by a vector signal generator (VSG). All of the interference sources are coupled into the receive path of the RA under test while it is connected to the optical delay panel for altitude simulation. Because no interference from WAIC systems was considered in this testing, the VSG is used only to simulate OoBI signals.

3.2. Experimental Setup Details

3.2.1 Aggressor RA Simulation

As shown in Figure 3, sixteen VCOs generated uncorrelated FMCW signals centered at 4300 MHz to represent emissions from other RAs. VCOs 1 and 2 simulated the redundant altimeters on board the victim aircraft (own-ship). Given that the redundant RAs are typically of the same make and model, VCOs 1 and 2 were configured to replicate the transmission characteristics of the victim altimeter. The simulated power levels of these own-ship RA interferers were set based upon the transmit power of the RA under test and the minimum allowed or expected antenna isolation between RAs in a multiplex installation.

For the WCLS test case, VCOs 3 through 16 represent four aggressor aircraft on the taxiway with triplex RA installations and one aggressor aircraft on the apron with a dual RA installation. The FMCW sweep characteristics of the RA interferers onboard aggressor aircraft were chosen to replicate a random mix of RA models, and the simulated power levels of these interferers were calculated based on the geometry of the WCLS. As previously described, for the 1000 ft and 2000 ft test scenarios, only the own-ship VCOs are used.

The individual VCO sweep characteristics and power levels at the receive port of the victim RA are listed in Table 1 and Table 2 for the aggressor aircraft on the ground and the redundant own-ship RAs, respectively.

Table 1: Aggressor VCO Signal Characteristics for 200' Test Case (Centered at 4300 MHz)

VCO No.	3	4	5	6	7	8	9	10	11	12	13	14	15	16
Power (dBm)	-86	-86	-56	-56	-56	-56	-56	-56	-79	-79	-79	-79	-79	-79
Sweep Rate (Hz)	143	111	133	133	133	118	118	118	111	129	129	129	143	143
Sweep BW (MHz)	133	131	131	124	132	135	132	132	124	130	129	131	131	132

Table 2: Own ship VCO Signal Characteristics (Centered at 4300 MHz)

Altimeter Under Test	Transmit Power (dBm)	Sweep Rate (Hz)	Sweep BW (MHz)	VCO 1&2 Output Power
Type 1	30	153.8	130	-30
Type 2	20	455	123	-40
Type 3	20	455	123	-40
Type 4	26	71.3/75	150	-34
Type 5	29	90/100	100	-40
Type 6	N/A	N/A	N/A	N/A
Type 7	N/A	N/A	N/A	N/A

3.2.2 OoBI Signal Simulation

A Rhode and Schwarz SMW200A VSG was used to generate simulated OoBI signals of varying bandwidths and power levels. Because no signal characteristics, modulation waveforms, or multiplexing schemes have been defined for the potential expanded use of the 3700 – 4200 MHz band, it was necessary to evaluate the susceptibility of each RA under test to the most generic OoBI signal possible. To do this, the OoBI test waveform was selected to provide a nearly uniform power spectral density (PSD) across a given signal bandwidth in order to represent a fully-occupied spectrum allocation within the bandwidth. As a matter of convenience, this uniform PSD signal was generated by means of an orthogonal frequency-division multiplexing (OFDM) waveform with binary phase-shift keying (BPSK) modulated subcarriers using random baseband data.

To characterize the response of the RA under test to different possible allocations within the 3700 – 4200 MHz band, the bandwidth of the OoBI waveform was varied between 50 and nearly 500 MHz, with the lower band edge always remaining fixed at 3700 MHz. This approach illustrates the gradually increasing susceptibility of RAs to OoBI as the usage of the 3700 – 4200 MHz band expands towards the lower RA band edge at 4200 MHz. A spectrum analyzer display of the OoBI test waveform with a bandwidth of 300 MHz is shown in Figure 4.

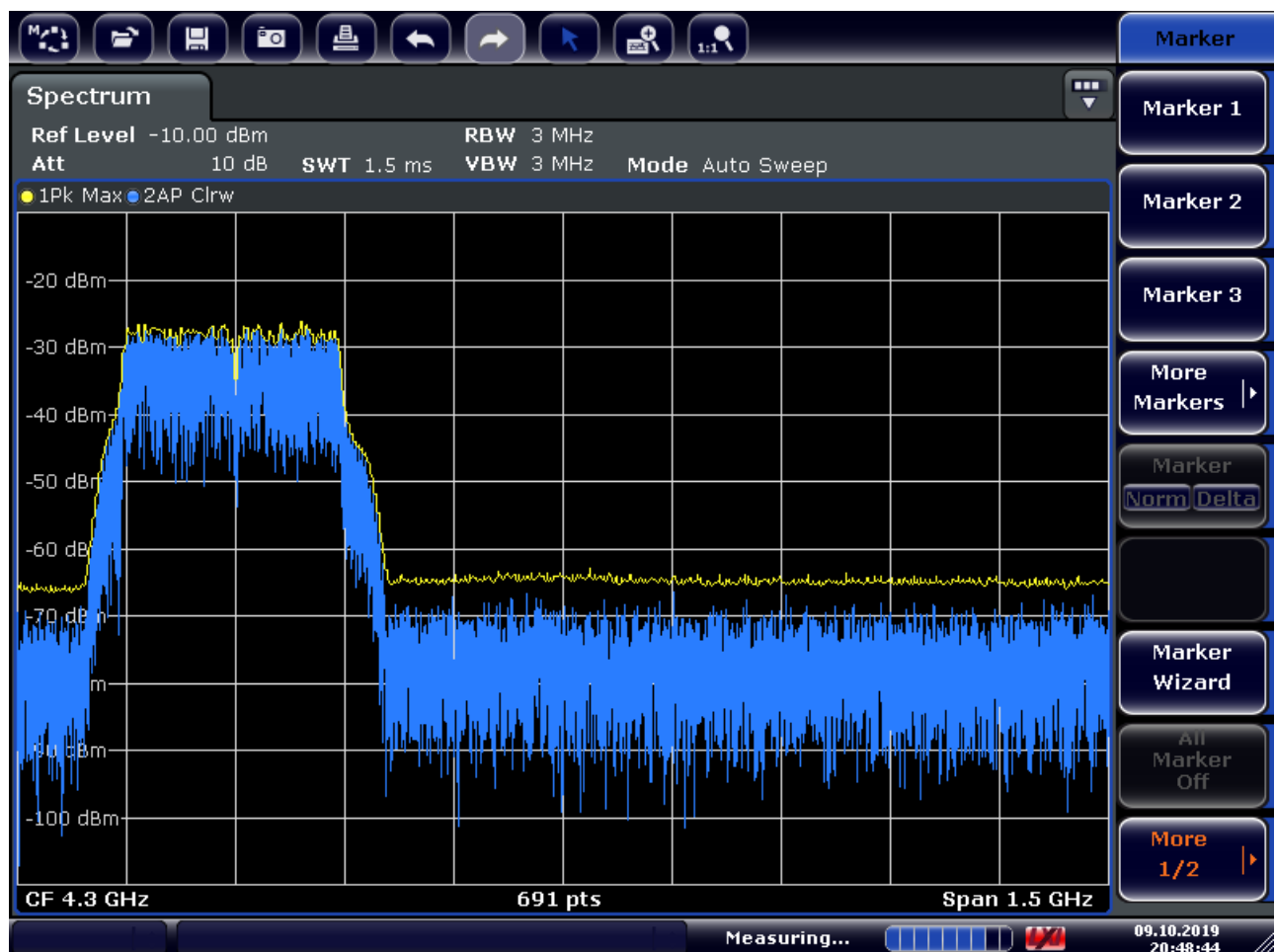

Figure 4: 300 MHz OoBI Waveform Centered at 3850 MHz Pictured on a Spectrum Analyzer.

3.2.3 Attenuation Calibration

A calibrated network analyzer was used to measure loss in the experimental setup in order to accurately determine the total loop loss value for each test altitude and ensure those values match that specified in the radio altimeter MOPS. All connectors were torqued as recommended and cables immobilized to ensure repeatability during calibration and subsequent testing. Attenuation values were recalibrated after any changes to the configuration.

3.2.4 Other elements of the experimental setup

Altitude measurements were obtained from the ARINC 429⁹ digital output of the RA under test. The effects of interference were determined by measuring changes in the reported altitude induced by the various interference conditions. A commercial ARINC 429 to USB interface (Ballard UR1420) was used to read data into the experimental control and data acquisition computer, which ran Ballard “Co-Pilot” software to capture, time-stamp, and log the data. Post-processing scripts and inter-range instrumentation group (IRIG) timing signals were used to ensure that the data time-stamped by the Ballard unit was correlated to the internal clock of the control computer, which in turn ensured time correlation between the computer-controlled interference stimuli and the RA responses.

3.3. Experimental Procedure

3.3.1. Out of Band Interference Signals

A single experiment consisted of increasing the OoBI interference power in steps of 1 dBm over a VSG output power range that produced an interference power at the RA RX port in the range of -30 dBm to 0 dBm, while the reported altitude was continuously recorded. Each power step included an initial period during which the RF output was turned off at the VSG followed by a period during which the RF power was turned on. The initial period provided the correct height reading used as a reference to measure the effects of interference with the RF power turned on. All altimeters were turned on prior to testing to allow sufficient time to stabilize operation.

The reported altitude was recorded using the Ballard Co-pilot software, which included an independent time stamp generated by the bus converter. The software stored the time-stamped readings in a database. This recorded data was subsequently post processed. Measured attenuation values were used to scale the interference power output by the VSG to that at the receive port of the RA.

A typical “power sweep” plot obtained by this process is shown in Figure 5 for a 10s on / 7s off interference signal. This plot shows the reported altitude (blue trace corresponding to values on left vertical axis) superimposed on the time-varying interference power (green trace corresponding to values on right vertical axis). It also shows $\pm 2\%$ error limits (red horizontal lines), corresponding to the RA accuracy requirements in ARINC 707,¹⁰ and data points at which the altimeter was unable to reliably report a computed altitude (red points along the blue trace). These unreliable altitude readings are output on the 429 bus along with an error flag that indicates No Computed Data (NCD). Criteria for reporting NCD can vary with the specific signal processing design in the various altimeters, but it is generally indicative of a condition in which the signal-to-noise ratio of the received FMCW signal is insufficient to compute an altitude with the required level of confidence.

⁹ ARINC Specification 429P1-19, *Digital Information Transfer System (DITS), Part 1, Functional Description, Electrical Interfaces, Label Assignments and Word Formats*, Aeronautical Radio, Inc. (2019).

¹⁰ ARINC Characteristic 707-7, *Radio Altimeter*, Aeronautical Radio, Inc. (2009).

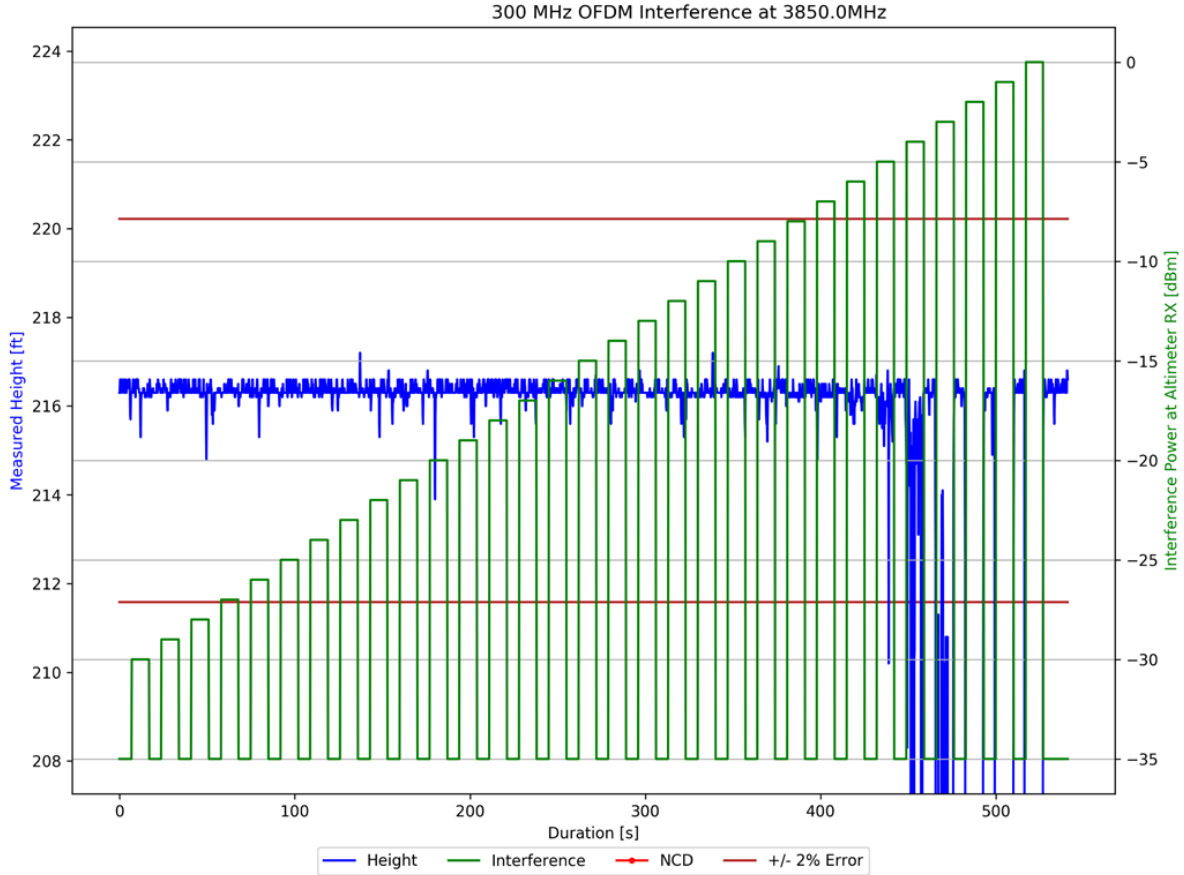

Figure 5: Typical Power Sweep Plot.

Table 3: VSG Signal Parameters for OoBI Simulation

Interference Signal			OoBI Power at Victim RA Receive Port			Power Durations	
Modulation	Bandwidth	Center	Min	Step	Max	ON	OFF
OFDM	50 to 480 MHz in steps of 50 MHz	3950 to 4140 MHz in steps of 50 MHz	-30 dBm	1 dB	0 dBm	10 seconds	7 seconds

Sufficiently long dwell sweeps were taken to ensure adequate data sample size to fully characterize the quasi-random interference signals and thus enable more accurate determination of the threshold power (see Section 3.4). This type of analysis led to plots of the type shown in Figure 6, which are termed “statistical plots” herein. The power sweeps were repeated for each OoBI bandwidth of interest.

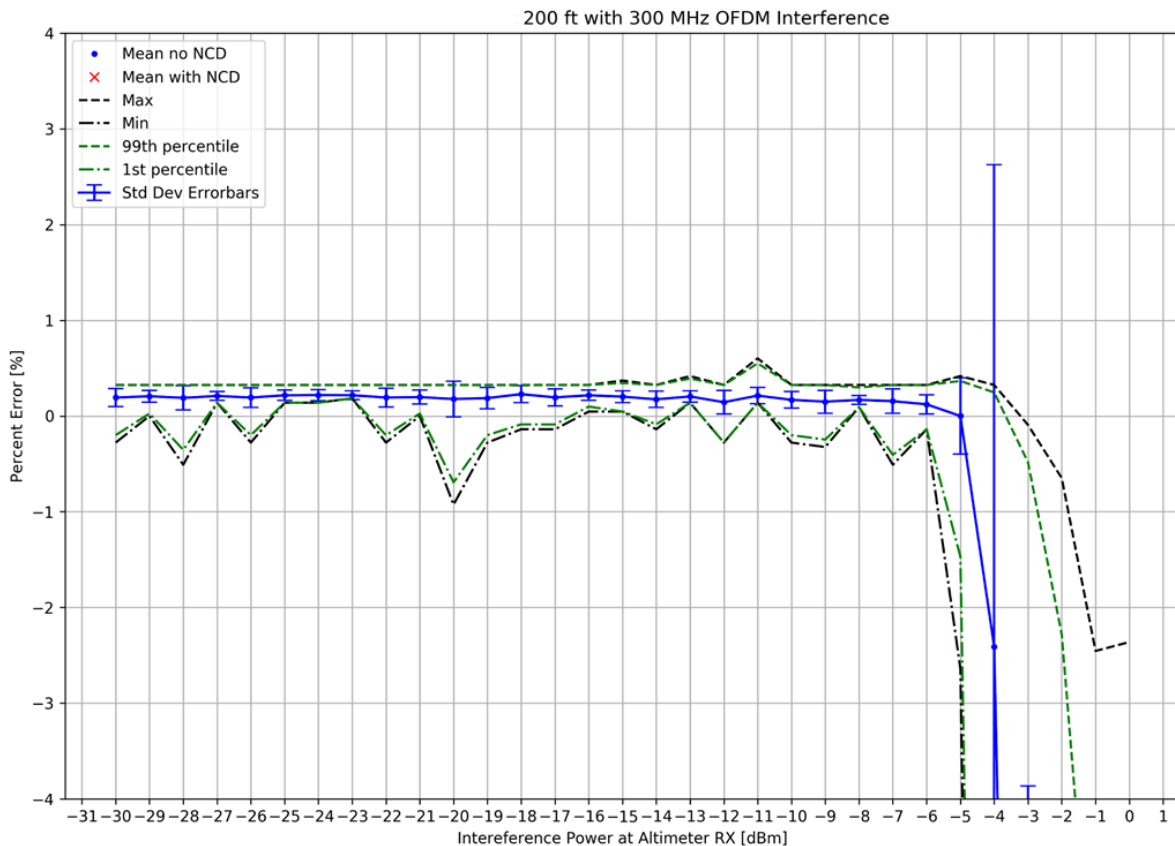

Figure 6: Typical Statistical Plot.

3.3.2. Tests at Multiple Altitudes

The information below is a summary of the details of the test setup and configuration for each altimeter at each tested altitude. Some of this information is redundant from previous sections of this report but is repeated for the sake of clarity and conciseness.

3.3.2.1. 200 Feet

Altimeters Type 1 through Type 7 were tested using the following conditions:

- OoBI signal power varied between -30 dBm to 0 dBm in steps of 1 dBm.
- OoBI power applied for a duration of 10 seconds and turned off for 7 seconds as shown in Table 3.
- OoBI bandwidths varied from 50 MHz to 450 MHz in steps of 50 MHz, as well as 480 MHz, with corresponding center frequencies varied so that the lower frequency edge of the OoBI signal was always at 3700 MHz (to attempt to account for as many 5G spectrum options as possible being considered by the FCC).
- RX and TX cable loss simulated at 3 dB for each cable (total cable loss of 6 dB).
- Total loop loss from altimeter TX to RX port set to 96 dB (90 dB loop loss + 6 dB cable loss).
- Own-ship VCOs (1 – 2) set to match the power and installation requirements of the RA under test as shown in Table 2. Output power shown in Table 2 is measured at the altimeter RX port.

- Aggressor VCOs (3 – 16) set according to Table 1.
- Deviations to the above conditions for specific altimeters are as follows:
 - Altimeter Type 1 did not operate successfully with 96 dB loop loss due to the presence of in-band RA interferers, which are not a part of standard test configurations in accordance with the MOPS. To resolve this, the loop loss was reduced to 94 dB.
 - Altimeter Type 4 did not operate successfully with 96 dB loop loss due to the presence of in-band RA interferers, which are not a part of standard test configurations in accordance with the MOPS. To resolve this, the loop loss was reduced to 93 dB.
 - For Altimeter Type 5, the power levels of the own-ship RA interferers were set based on an assumed antenna isolation of 70 dB on the victim aircraft rather than the 60 dB minimum isolation called out in ARINC 707. This isolation value was chosen in accordance with the manufacturer’s recommendations in the installation manual.
 - Altimeters Type 6 and Type 7 are not typically installed in a multiplex (multiple altimeter) configuration, so VCOs 1 and 2 (representing own-ship RA interferers) were not used.

3.3.2.2. 1000 Feet

Altimeters Type 1 through Type 7 were tested using the same criteria as the 200 feet testing with the following changes:

- Total loop loss from altimeter TX to RX port set to 110 dB (102 dB loop loss + 6 dB cable loss).
- Aggressor VCOs (3 – 16) not used, as the victim aircraft is sufficiently far from aggressor aircraft on the ground that interfering signals will not affect operation.

3.3.2.3. 2000 Feet

Altimeters Type 1 through Type 7 were tested using the same criteria as the 1000 feet testing with the following changes:

- Total loop loss from altimeter TX to RX port was set to 116 dB (110 dB loop loss + 6 dB cable loss).

3.4. Threshold Power Criteria

3.4.1. Definition of Correct Height

The term nominal height is used to refer to the approximate altitude simulated by the experimental test setup. The difference between measured height and the nominal height of the setup varies between the different altimeters and is primarily a result of different calibration settings for each altimeter. The installation calibration procedure is an important part of installing an altimeter onto an aircraft. When an aircraft is on the ground, the transmit and receive antennas used by the altimeter are naturally several feet off the ground. Additionally, standardized delays from the altimeter transmit port to the transmit antenna and from the receive antenna to the receive port are utilized, known as Aircraft Installation Delays (AIDs). To compensate for the varying heights of airframes, as well as the AID of the installation, avionics manufacturers utilize calibration procedures to ensure that installed altimeters output an altitude of 0 feet when the aircraft is on the ground.

Because the tests in these studies are concerned with a differential height error, rather than the accuracy of an absolute altitude measurement, nominal height is only used to set the loop loss. The baseline measured height with no interference (“correct height” herein) is then calculated in post-

processing as the median altitude reported by the RA under test over the initial RF power off interval for each power step. Any height error attributable to interference is measured as a variation from this correct height. Thus, installation calibration of each altimeter is unnecessary for this test procedure.

3.4.2. Interference Power Threshold

Early tests showed that powerful interference signals would not only cause the reported altitude to exceed the $\pm 2\%$ accuracy limit specified in ARINC 707, but also cause a distortion of the mean reported altitude. Thus, a more conservative set of criteria for determining the interference power threshold was used that included at least one of the following interference conditions:

1. A mean height error greater than 0.5%,

$$\frac{|Average\ Height(RF\ on) - Average\ Height(RF\ off)|}{Average\ Height(RF\ off)} * 100\% > 0.5\%$$

2. Fewer than 98% of all data points in the RF power on interval fall within the $\pm 2\%$ limits specified by ARINC 707,

$$H_{1\%} < (Average\ Height(RF\ off) - 2\%) \text{ or } H_{99\%} > (Average\ Height(RF\ off) + 2\%)$$

(where $H_{x\%}$ is defined as the value for which x% of all heights reported during the measurement interval fall outside the 1% to 99% height interval)

3. Any height reading which reported NCD.

4.2. Aggregate Test Results for Altimeters at 1000 Feet

Figure 8 shows the aggregate results of the 1000 ft tests.

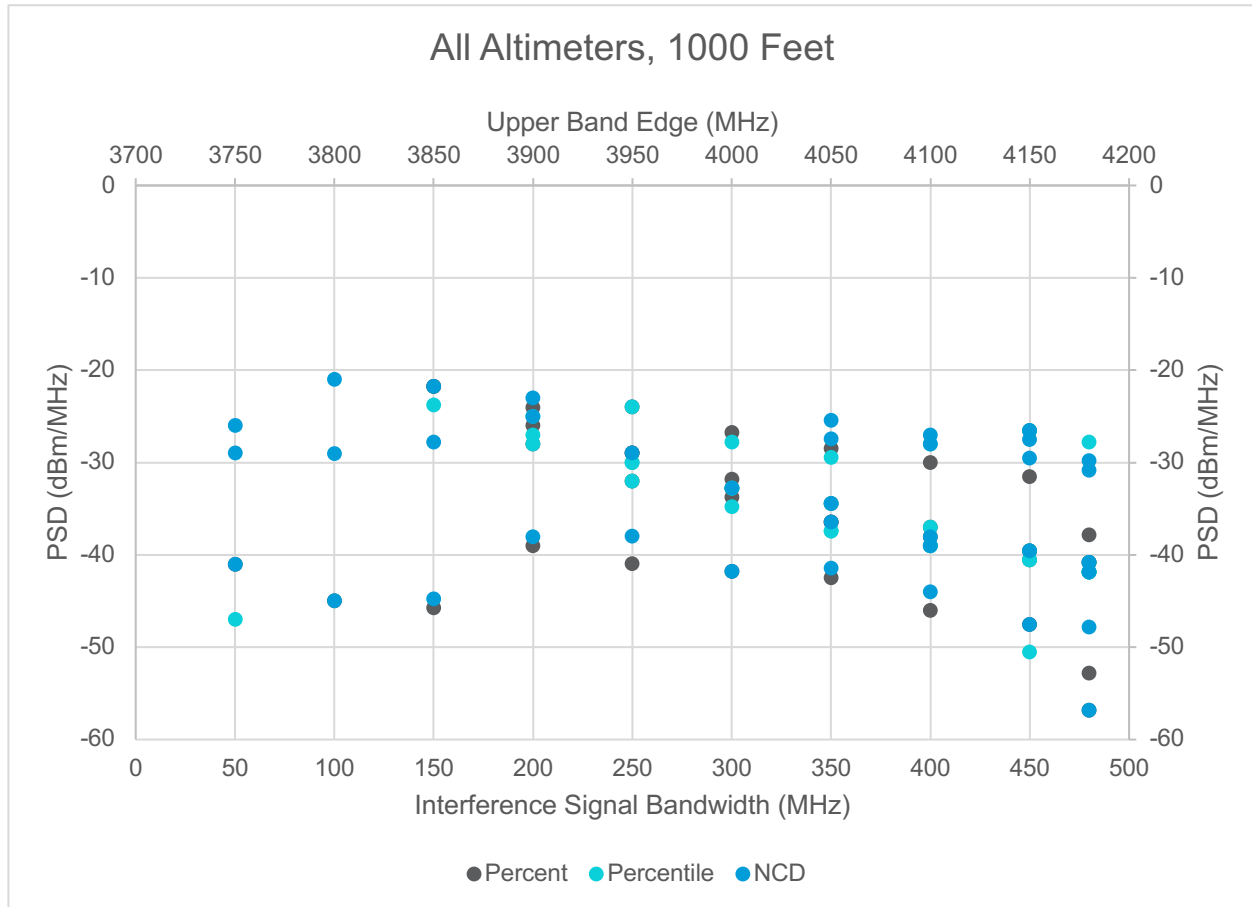

Figure 8: Aggregate Plot of Altimeter Break Points, 1000 Feet.

4.3. Aggregate Test Results for Altimeters at 2000 Feet

Figure 9 shows the aggregate results of the 2000 ft tests.

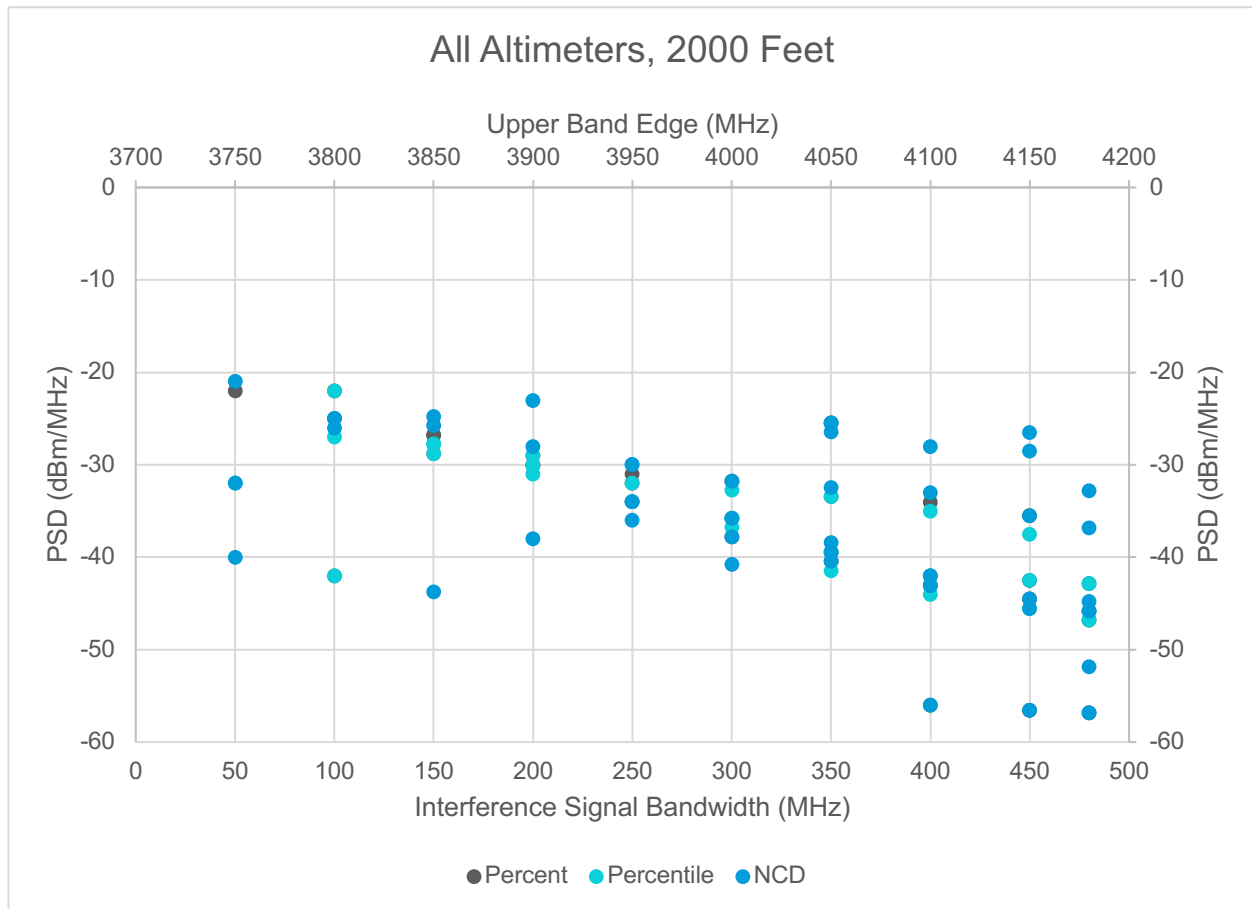

Figure 9: Aggregate Plot of Altimeter Break Points, 2000 Feet.

4.4. Commentary on Preliminary Results

As initially discussed in Section 2.4, the radio altimeters selected for this study represent a broad usage base in commercial air transport, business aviation, general aviation, and helicopter aircraft. All altimeters tested are FAA approved devices which claim either TSO-C87¹¹ or TSO-C87a¹² compliance and are in operation in all phases of flight across the US.

The recorded results appear to define the altimeters into two separate performance profiles. For Altimeter Types 1 through 6, susceptibility to OoBI PSD levels is reported at a broadly consistent level until more than approximately 200-250 MHz of OoBI from simulated 5G spectrum is introduced (starting at the 3700 MHz band edge). At that point, there appears to be a slow decrease in the altimeter's

¹¹ TSO-C87, *Airborne Low-Range Radio Altimeter*, Federal Aviation Administration (1966). Although TSO-C87 has since been superseded by TSO-C87a, the performance requirements of both are substantially the same. Devices certified under TSO-C87 may still be manufactured under the provisions of the original FAA approval and are widely deployed in aircraft operating worldwide.

¹² TSO-C87a, *Airborne Low-Range Radio Altimeter*, Federal Aviation Administration (2012).

tolerable PSD levels as OoBI interference bandwidths grow to 480 MHz, with the acceptable PSD of OoBI interference decreasing by as much as 30 dB. This trend is consistent across all three test altitudes and can be observed in Figure 10, which shows the minimum measured interference breakpoint across this group of altimeters for each signal bandwidth. Note that although this plot only includes the minimum breakpoints for Altimeter Types 1 through 6, the results obtained for each of the altimeters in this set were fairly consistent and exhibited the same general trend, as seen in the plots in Section 0 above. Figure 10 illustrates this trend for all three altitudes, with minimal clutter from additional data points.

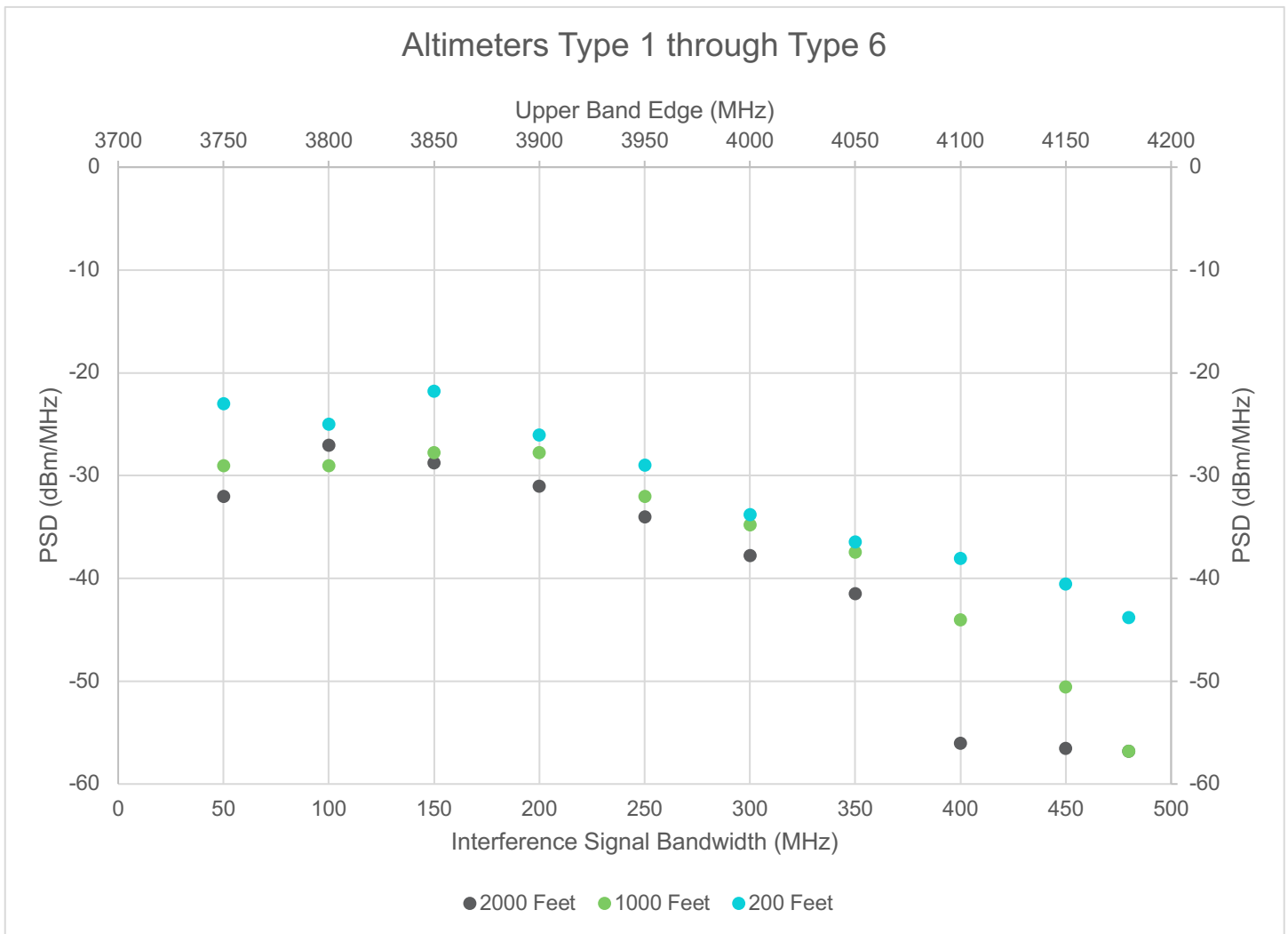

Figure 10: Minimum Break Points of Altimeter Types 1 – 6 for Each Altitude Tested.

The second performance profile was observed for Altimeter Type 7 only, which appeared to exhibit a noticeable difference in OoBI performance from the other altimeters, recording the lowest performance across almost all altitudes and interference signal bandwidths. This was most prominent at the 200 ft altitude test setting, with an identifiable set of data points at lower PSDs than other altimeters. Performance at higher test altitudes appeared somewhat closer to the data from other altimeters but was still recorded as more susceptible to OoBI for the majority of generated bandwidths. These behaviors are illustrated in Figure 11, which shows the measured interference breakpoints for Altimeter

Type 7 across all three test altitudes. Note that for some of the data points shown in this figure, the measured breakpoint was at the lowest possible interference signal power used in the test. Therefore, in such cases the actual maximum tolerable interference PSD may be lower than what was observed during testing.

Despite the difference in susceptibility to OoBI compared to the other altimeters tested, it is critical to state that Altimeter Type 7 is still an FAA approved device and has thus demonstrated compliance with applicable radio altimeter MOPS. Furthermore, this altimeter is known to be widely deployed in the cost-sensitive general aviation, lower-end business aviation and smaller helicopter market segments and sees substantial usage with a large installation base up to the present day. Lastly, this altimeter, like all altimeters, computes and reports altitude in a proprietary manner, thus analysis of its performance required unique post-processing. The testing group believes that additional testing and validation will be required on this specific altimeter to determine if the results can be further refined.

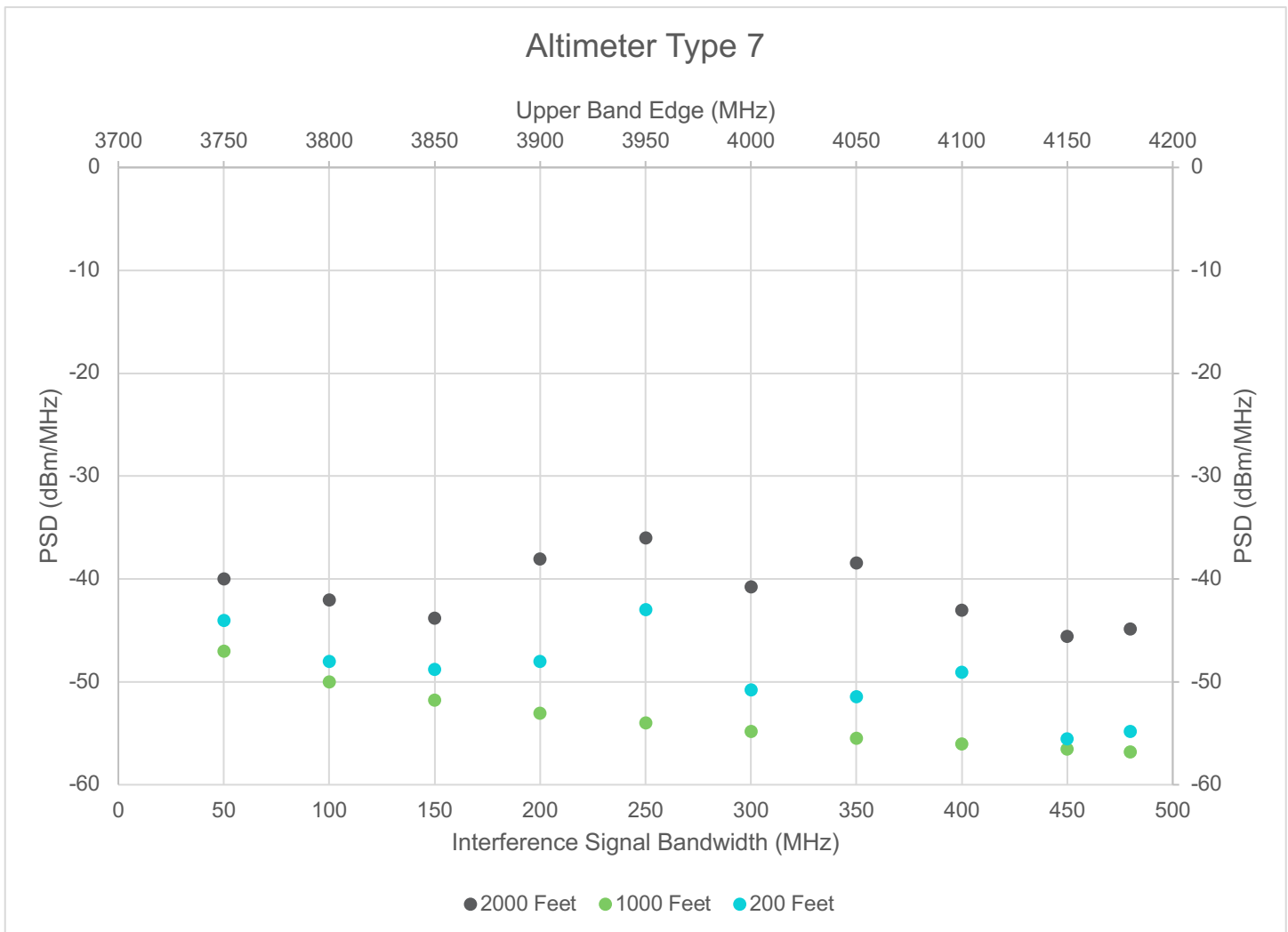

Figure 11: Minimum Break Points of Altimeter Type 7 for Each Altitude Tested.

5. Summary and Initial Conclusions

The AVSI test group wishes to reiterate several important caveats to the test results presented in this report:

- This data is considered very preliminary and has been released ahead of schedule to ensure the FCC has initial data to consider in its NPRM process.
- These initial results have been organized to account for some, but not all, potential 5G scenarios being considered by the FCC in its NPRM. Additional configurations of 5G network deployments may also need to be considered as plans for 5G are finalized.
- While the altimeters considered in the testing are representative of the majority of systems fielded by commercial and private aviation, it is not a comprehensive set of data for all altimeters operating under all conditions. Therefore, an additional variance in performance should be expected and accounted for, as plans for 5G are finalized.
- This report does not consider the operational interactions between aircraft and wireless base stations/user equipment. The AVSI project team strongly recommends that any study consider the worst-case flight and 5G deployment scenarios to account for all possible RF interactions with RAs, including with the involvement of the FAA to assure public safety in the national airspace. Studies should also include necessary extra safety margin to account for unknown elements in any analysis as required by International Civil Aviation Organization (“ICAO”) when conducting such studies.

In reviewing the preliminary data, there is a clear performance difference in altimeters as an increasing amount of OoBI was received by the RAs from the 3700 – 4200 MHz band. For all three altitude scenarios tested, most of the altimeters reported broadly consistent susceptibility to OoBI PSD levels until more than approximately 200 to 250 MHz of OoBI was introduced (starting at the 3700 MHz band edge). At this point the acceptable levels of PSD began to decrease as OoBI spectrum occupancy increased towards the 4200 MHz band edge.

Although most of the altimeters tested followed the trend described above, one altimeter reported an apparent lower interference PSD threshold than other devices for most test points, especially at lower altitudes. As stated previously, it should be noted that this device is a significantly lower cost altimeter (while still carrying FAA design approval) for different aircraft market segments than the other devices tested and is widely deployed in the market. Additionally, the types of aircraft this altimeter is typically installed on are more likely to operate within closer proximity to the ground and away from main airports. In review, the test group believes more work may be needed to properly catalogue the performance of these types of altimeters.

The AVSI group will continue its testing to further develop and validate the test results and better define additional performance parameters, though these may not meet the timelines of the FCC NPRM process. The group is also attempting to acquire additional altimeters to provide an even wider study of radio altimeters in use. Essential to the above work is better defining what 5G RF environment radio altimeters might encounter at various altitudes during aircraft operation, since the current FCC record contains many proposals that could result in different outcomes for the safe operation of aircraft. Finally, given the number of variables which must be accounted for during testing, the group is open to comments from those parties interested in further development and validation of the testing presented in this report.